

K12 Flat Round Air Bearing with piston preload

Technical Details Piston Bearing:

Diameter	12 mm
Air Gap	8.5 μm
Stroke Piston	± 1 mm
Air Flow ¹	1.4 sl/min
Weight (with piston)	10 g
Preload Force (@ $p_{\text{Piston}} = 5.0$ bar)	17 N
Relative Preload Force ²	3.4 N/bar
Air Pressure Piston ¹	7.3 bar
Material / Finish Air Bearing	Aluminum / Hard Anodized
Material Face Surface	Aluminum / Hard Anodized
Order No.:	K12-2 / 117

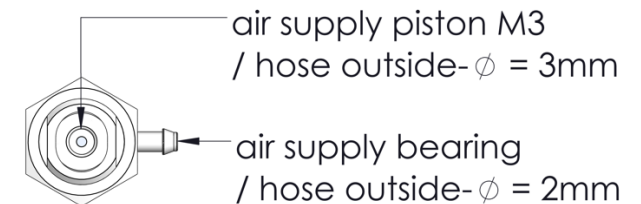
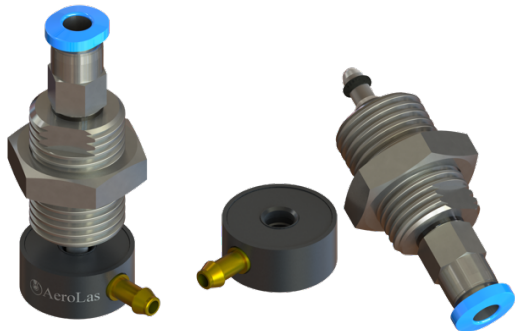
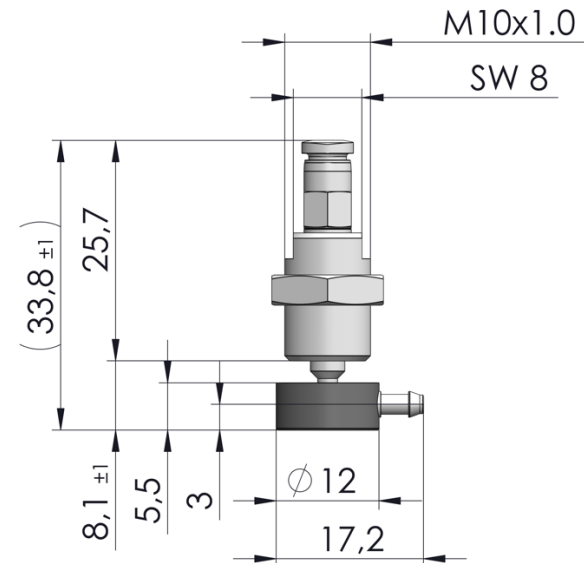

¹ Specifications at an operating pressure of the air bearing of 5.0 bar.

² The pressure of the piston and consequently the preload can be adjusted independently of the supply pressure of the air bearing.