

K45 Flat Round Air Bearing with piston preload

Technical Details Piston Bearing:

Diameter	45 mm
Air Gap	9.0 μm
Stroke Piston	± 1 mm
Air Flow ¹	3.0 sl/min
Weight (with piston)	87 g
Preload Force (@ $p_{\text{Piston}} = 5.0$ bar)	255 N
Relative Preload Force ²	51 N/bar
Air Pressure Piston ¹	max. 9.2 bar
Material / Finish Air Bearing	Aluminum / Anodized
Material Face Surface	Epoxy Glide Coating
Order No.:	K45-6 / 135

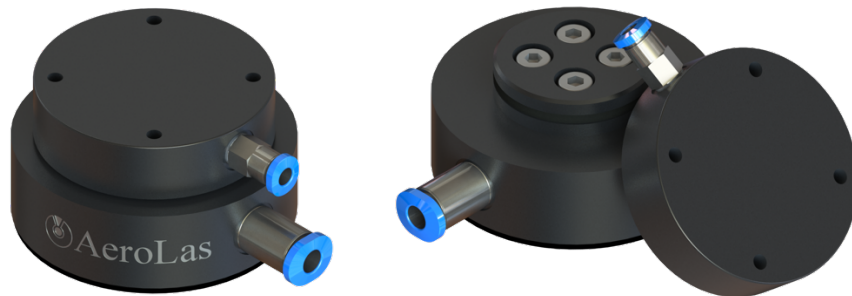
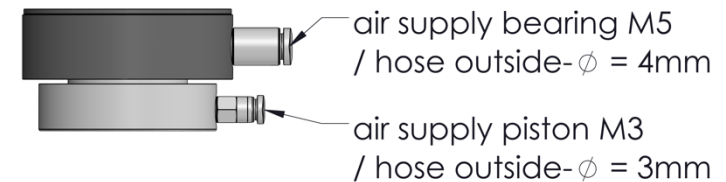
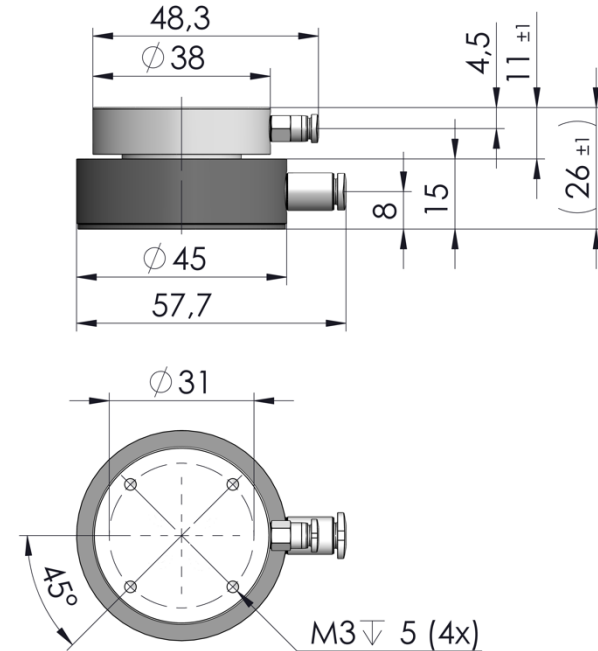

¹ Specifications at an operating pressure of the air bearing of 5.0 bar.

² The pressure of the piston and consequently the preload can be adjusted independently of the supply pressure of the air bearing.