

R75 Flat Rectangular Air Bearing with piston preload

Technical Details Piston Bearing:

Length Width	75 mm 55 mm
Air Gap	8.5 μm
Stroke Piston	± 1.3 mm
Air Flow ¹	3.0 sl/min
Weight (with piston)	210 g
Preload Force (@ $p_{\text{Piston}} = 5.0$ bar)	625 N
Relative Preload Force ²	125 N/bar
Air Pressure Piston ¹	max. 9.6 bar
Material / Finish Air Bearing	Aluminum / Anodized
Material Face Surface	Epoxy Glide Coating
Order No.:	R75-2 / 121

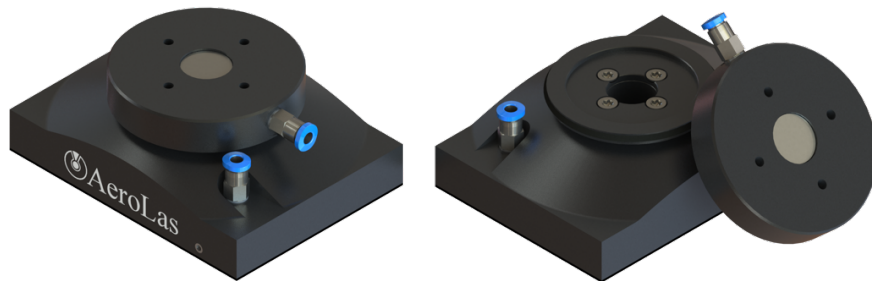
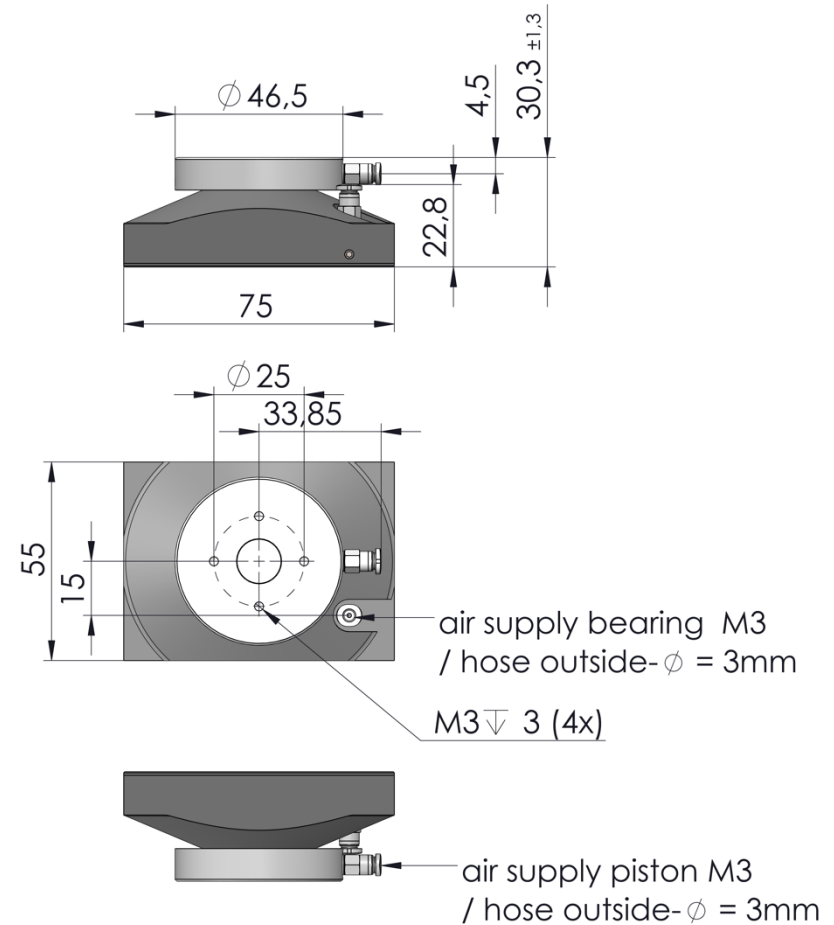

¹ Specifications at an operating pressure of the air bearing of 5.0 bar.

² The pressure of the piston and consequently the preload can be adjusted independently of the supply pressure of the air bearing.

Note: Piston is permanently connected to the air bearing and cannot be disassembled.