

R90 Flat Rectangular Air Bearing with piston preload

Technical Details Piston Bearing:

Length Width	90 mm 71 mm
Air Gap	9.5 μm
Stroke Piston	± 1.3 mm
Air Flow ¹	4.8 sl/min
Weight (with piston)	389 g
Preload Force (@ $p_{\text{Piston}} = 5.0$ bar)	1,230 N
Relative Preload Force ²	246 N/bar
Air Pressure Piston ¹	max. 8.1 bar
Material / Finish Air Bearing	Aluminum / Anodized
Material Face Surface	Epoxy Glide Coating
Order No.:	R90-2 / 115

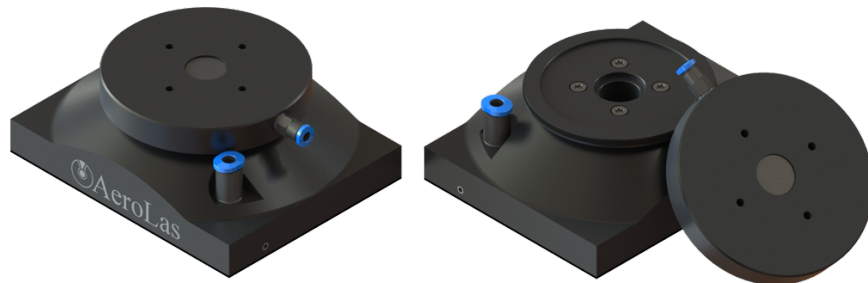
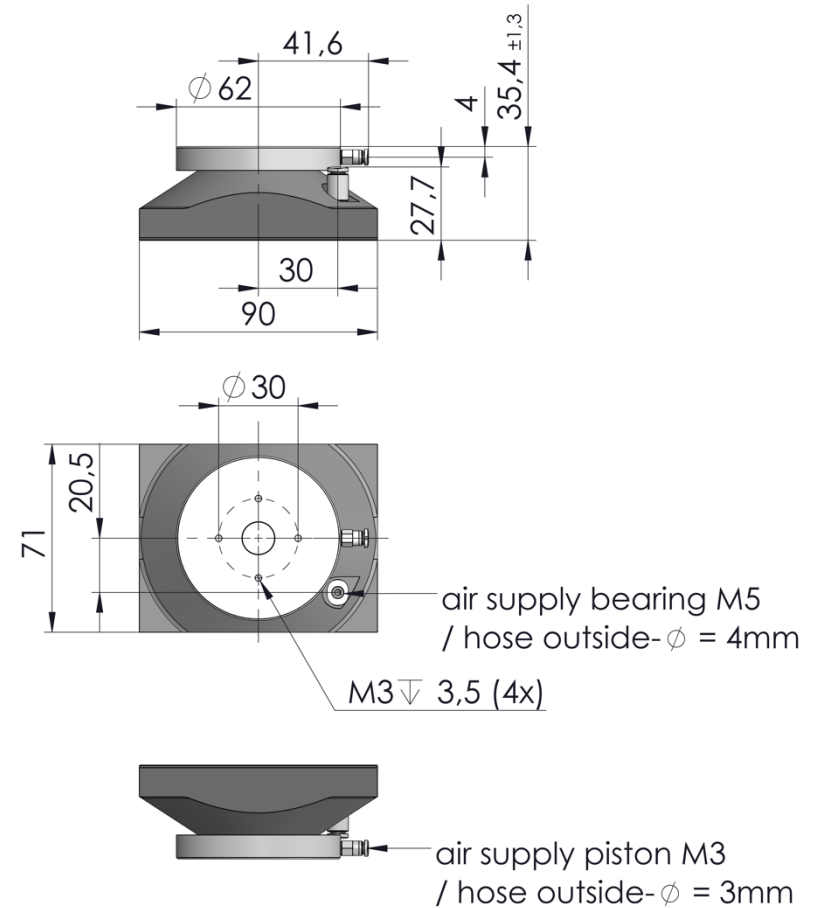

¹ Specifications at an operating pressure of the air bearing of 5.0 bar.

² The pressure of the piston and consequently the preload can be adjusted independently of the supply pressure of the air bearing.

Note: Piston is permanently connected to the air bearing and cannot be disassembled.